

UNI-SPENSE® III DRY INGREDIENT DISTRIBUTOR

Designed for high-volume production. The Uni-spense III offers the same reliability, accuracy, and performance as our standard Uni-spense.

Delivers uniform coating with "tools-free" operation. Unique adjustable teardrop openings and auger design allows for distribution of a variety of powders, granules, chopped and shredded products. Ideal for use in coating drum, blender and over the belt conveyor applications.

Standard Features

- 304 stainless steel construction
- "Tools-Free" product changeovers
- NEMA 4 fiberglass control console with variable speed control with digital readout
- Stainless steel supply hopper with vibrator and adjustable cycle timer
- Stainless steel distribution tube with worm gear adjustable teardrop openings
- Low, mid, or high volume auger with "tools-free" disconnect
- Inverter duty AC washdown motor

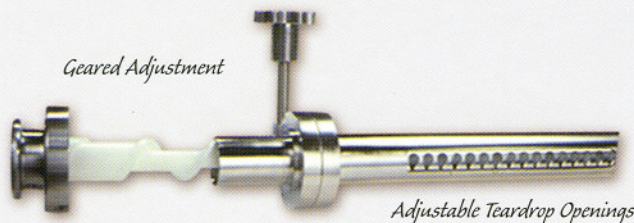

Uni-spense
Control Panel
(Stainless
Console Optional)



Tel: 636-629-7366
800-260-7366
Fax: 636-629-7455
www.spraydynamics.com



Spray Dynamics Ltd., 108 Bolte Lane, St. Clair MO 63077

UNI-SPENSE® III DRY INGREDIENT DISTRIBUTOR

AVAILABLE OPTIONS

- Powder Xpress® Material Transfer System
- Enhancer® Electrostatic Spice/Powder Applicator
- Delta Dry™ Loss-in-Weight System
- Custom length distribution tubes
- Stainless steel augers
- 4-20 m.a. or 0-10 volt D.C. input signal control
- Tube vibrator
- Deflector plate
- Portable stainless steel stand with casters
- Stainless steel control console

POWER SPECIFICATIONS

- 115/220 VAC, 50/60 Hz, single phase
- Variable speed A.C. motor controller with NEMA 4 enclosure
- 1/2 H.P. AC gear motor – standard

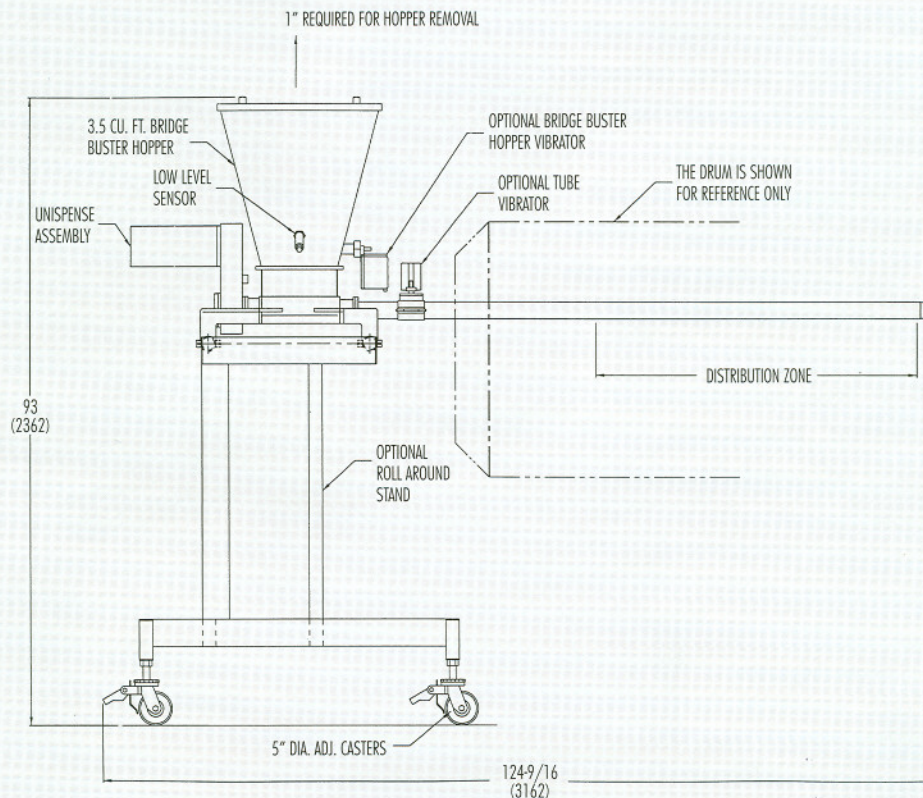

Tel: 636-629-7366
800-260-7366
Fax: 636-629-7455
www.spraydynamics.com



Spray Dynamics Ltd., 108 Bolte Lane, St. Clair MO 63077